

Studrails

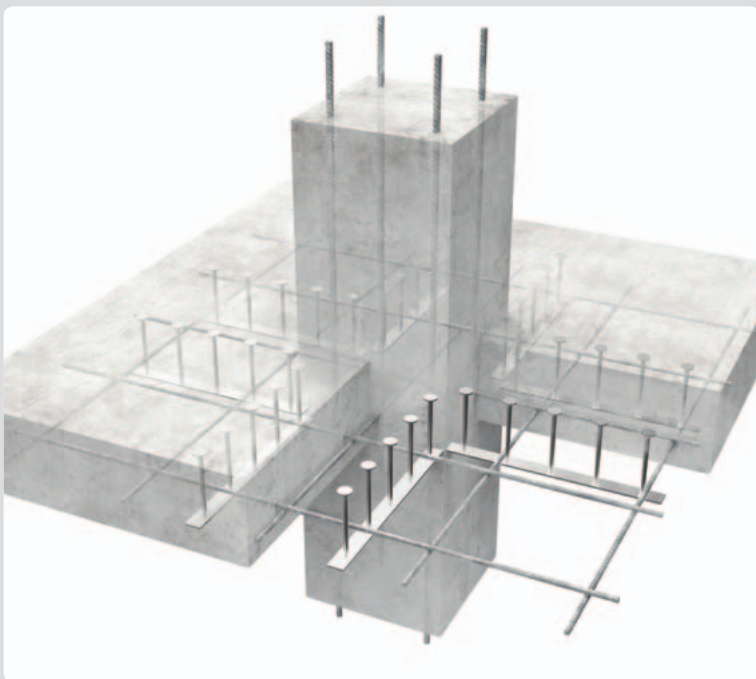
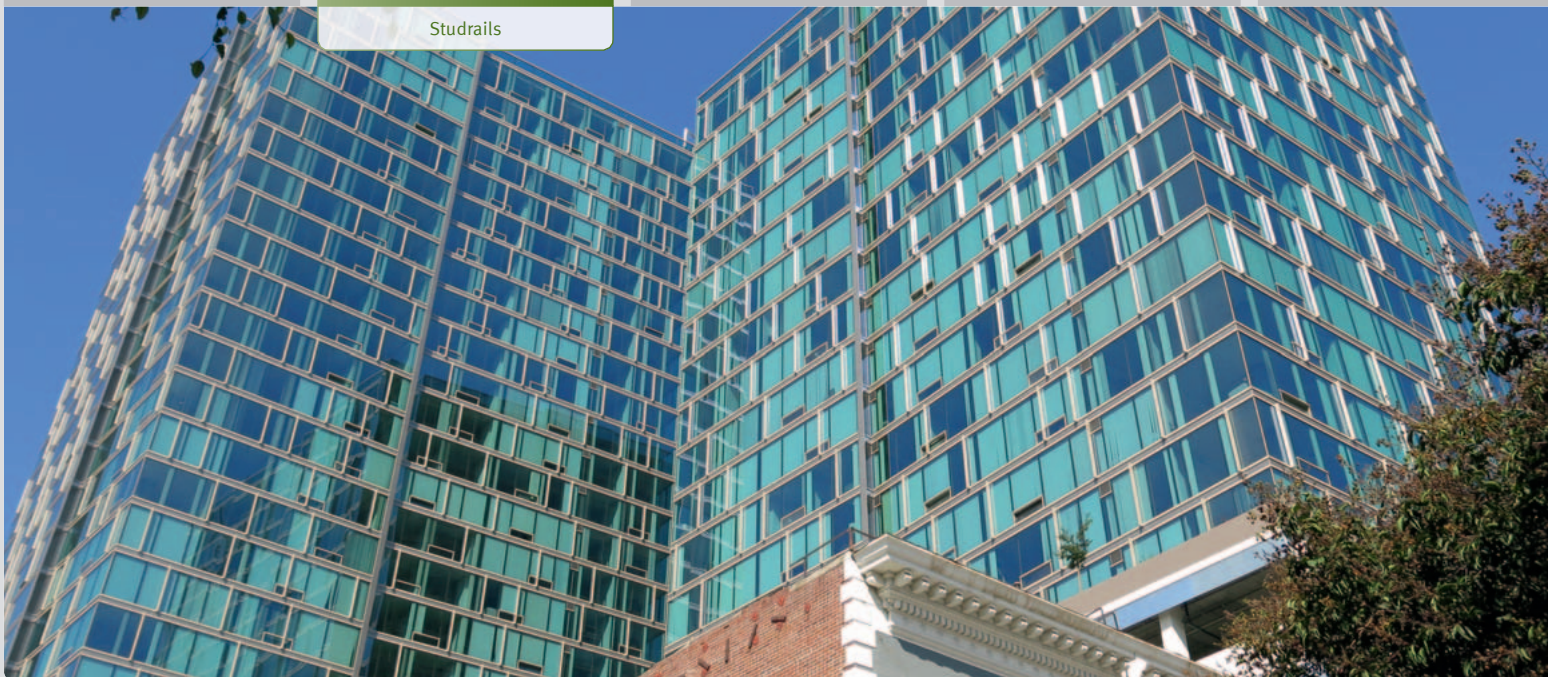

DECON® Studrail® Punching Shear Reinforcement

The Original Leader in Quality and Performance.

Technical Information



DECON

a JORDAHL company

Leading Concrete Reinforcement Technology since 1988



About DECON

The research and development on which the DECON® Studrails® product range is based goes back to the 1970s, when the University of Calgary began research to find an efficient, economical and simple solution to improve the punching shear resistance of concrete. This research led to the commercial development of Studrails® in Germany, and dramatically improved design for punching shear in flat slabs. The technology was commercially introduced back into North America by DECON in 1988.

Prior to the introduction of Studrails®, only fairly expensive and labor-intensive methods were available to enhance the punching shear capacity of the concrete floor slab area above columns. These traditional methods included placing additional stirrups in the slab to improve the steel reinforcement, introducing column capitals, or introducing I-beam shearheads. Each of these methods had its inherent problems such as cost, labor time needed for installation, and/or violating architectural constraints. Also, reinforcement testing showed measurable anchorage slip at reinforcement bends in thin slabs, reducing the effectiveness of stirrups and often requiring very congested slab reinforcement designs to compensate for anchorage slip.

DECON experienced widespread growth due to the acceptance and promotion of Studrails® by many well respected engineering and contracting firms across Canada and the United States. In 2009 the product range was expanded when DECON became the North American distributor of JORDAHL® anchor channels, and today the company is a fully owned subsidiary of JORDAHL GmbH, a German company with its own historical roots in North America.

The seeds of the JORDAHL company were planted at the start of the twentieth century by the invention of a concrete reinforcement system by Julius Kahn, a designer working in the USA. His brother Albert became world famous as the Principal of the US architectural firm Albert Kahn Associates. The new concrete reinforcement system was used extensively in the buildings designed by Albert.

In 1907, a new German company was established to market Julius Kahn's concrete reinforcement system in Europe. One of the principals of the new company was a Norwegian engineer named Anders Jordahl, who in 1913 invented the world's first cast-in anchor channel. Today, with over a hundred years of success, JORDAHL® anchor channels are used all over the world to allow adjustable and reliable connections to concrete structures.

By incorporating the best of North American and European technology, DECON continues to drive its business forward based on the principles of engineering excellence and the highest standards of customer service. Today, our North American offices are located in Sonoma, CA, Beaufort, SC, and Brampton, Ontario, Canada.

Contents

Introduction to Punching Shear Reinforcement	4
Advantages and Applications of DECON® Studrails®	5 – 6
Design	7 – 20
Introduction	7
Design Overview	8 – 11
■ Notation	8
■ Basic Design Steps	9
■ Studrail® Selection	9
■ Studrail® Positioning	10
■ Typical Studrail® Layouts	10 – 11
■ Typical Layouts Relative to the Critical Section	11
Seismic Design– Improving Slab Ductility	12
Example – Interior Slab Column Calculation	13 – 14
Example – Design of Studrails® for Ductility	15
Software	16 – 20
Specifying and Ordering DECON® Studrails®	21
Installation of DECON® Studrails®	22
Advice	23
Disclaimer of Warranties	23



'Avalon Irvine' apartment complex, Irvine CA



'The Village at Bella Terra', Huntington Beach CA

All rights reserved.
The right to make revisions within the framework of product and application-related, ongoing developments is reserved.

DECON USA, Inc.
103 East Napa Street, Suite B
PO Box 1486
Sonoma, CA 95476

Introduction to Punching Shear Reinforcement

Structures incorporating flat plate slab construction techniques save costs and allow optimum use of building space, but they can also cause increased punching shear loads at column locations.

Even in the early days of concrete structures, the problem of punching shear at the column head area was already recognized (Fig. 1). Mushroom construction was introduced around 1900 as a way of avoiding the arrangement with main transverse and auxiliary beams (Fig. 2).

Only a short time later the Kahn steel reinforcement system (Fig. 3) was used as tensile reinforcement. It consisted of upturned wings, which resisted transverse forces in the ceiling support area. The inventor of the Kahn steel reinforcement system, Julius Kahn, and his brother, the famous architect Albert Kahn, enjoyed great success with this product in the field of construction with reinforced steel concrete.

It was difficult to achieve thin floor slabs using conventional concrete reinforcement. To prevent punching shear at the columns it was often necessary to introduce column capitals or very congested reinforcement designs using stirrups (Fig. 4). Both are expensive and time-consuming solutions.

The more efficient design provided by DECON® Studrails® (Fig. 5) has resulted in the system becoming the most widely used solution in North America. The system eliminates column capitals and stirrups to speed construction, while enabling the design of an elegant and economical structure.

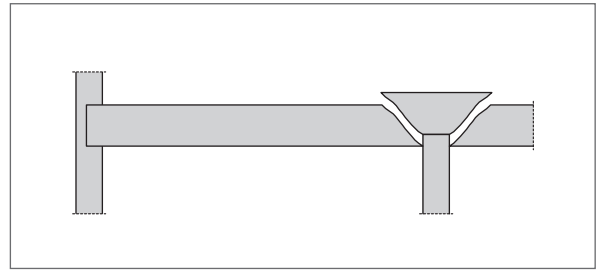

Fig. 1: Punching shear failure.

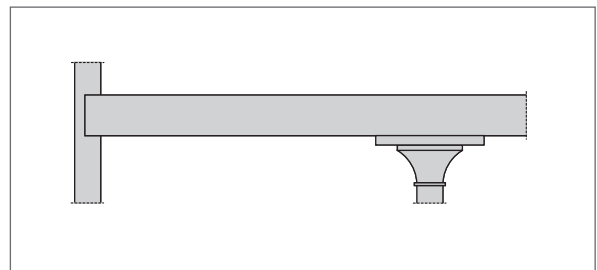

Fig. 2: Mushroom ceilings.

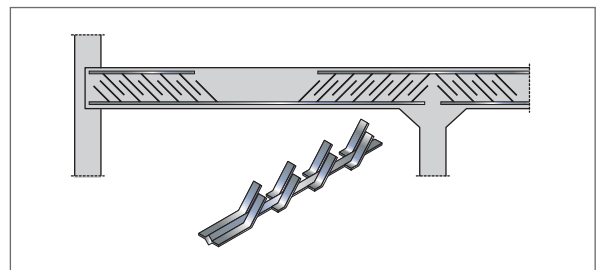

Fig. 3: "Kahn" steel reinforcement system.

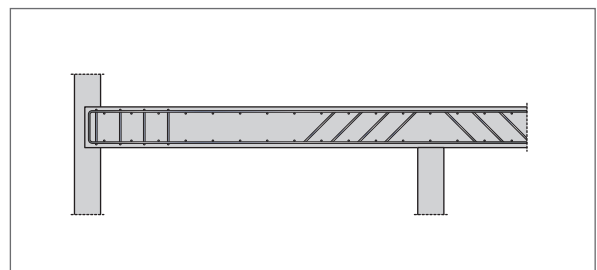

Fig. 4: Punching shear solutions using closely spaced stirrups.

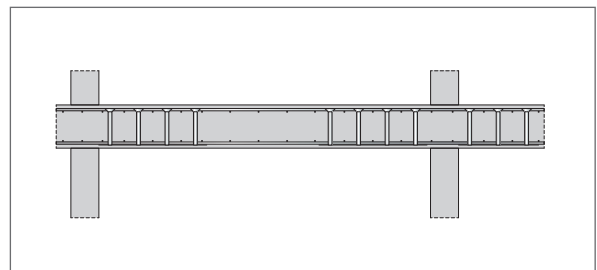

Fig. 5: DECON® Studrails® efficiently resist punching shear and enable flat slab construction.

Advantages and Applications of DECON® Studrails®

Studrails® are a technically excellent and economical solution to transfer high transverse forces in slabs and foundations. They offer the following advantages:

- Reduce installation time and effort versus conventional rebar stirrups and hairpins.
- Permit more efficient use of fly-forms.
- Jobsite-ready factory fabrication to guarantee weld quality, proper dimensions, correct spacing, and to enable location/type color-coding.
- Develop the full yield strength of the studs in tension making it possible to use thinner post-tensioned slabs in designs governed by shear.
- Provide predetermined stud locations, virtually eliminating field placement errors.
- Use specially designed chairs supplied with the Studrails® to ensure proper concrete cover.
- Allow greater versatility of design.

Slab-Column Connections with Studrails®

- Eliminate the need for column capitals and stirrups.
- Reduce congestion around slab-column connections, allowing quicker installation of conduit, PT tendons and other embedments.
- Distribute forces over a greater critical section to prevent punching shear.
- Provide higher ultimate strength and more ductile behavior of the concrete slab-column connection through efficient anchorage.
- Allow openings through the slab.

Banded Post-Tension Anchor Zones with Studrails®

Replace hairpin reinforcement with the following advantages:

- Eliminates congestion in post-tensioned tendon anchorage zones by replacing hairpins with a single line of Studrails®.
- Results in significant savings in time and labor.
- Reduced congestion allows better compaction of concrete behind the anchors, reducing the chance of blow-outs during stressing.
- Superior anchorage eliminates anchorage slip and enables DECON® studs to develop their full yield strength.
- Test results monitoring applied loads, anchor displacement, strain in the studs, and crack development, show that the performance of Studrails® surpasses that of hairpins while maintaining a significant reserve capacity at anticipated service loads.



Factory-welded Studrails® attached to the formwork with DECON® Clip Chairs and Star Chairs enable superior reinforcement performance combined with correct concrete cover and accurate stud positioning.



Studrails® enable flat slab construction and significantly reduce the congestion of punching shear reinforcement at columns.



Studrails® eliminate the need for hairpin reinforcement at tendon end locations easing reinforcement congestion.

Foundation Walls

Depending on the soil type and the depth of the structure below grade, there can be high out-of-plane shear stresses in perimeter foundation walls. Studrails® can be used instead of stirrups as one-way shear reinforcement to resist this lateral earth or hydrostatic pressure on foundation walls. A typical detail might have a series of Studrails® installed in the walls either just above and/or just below the slab.

Advantages compared to alternative designs using stirrups:

- Reduces congestion around the slab-wall connection, and allows faster installation.
- Distributes forces over a greater critical section to prevent punching shear.
- Provides higher ultimate strength and more ductile behavior of the slab-wall connection.

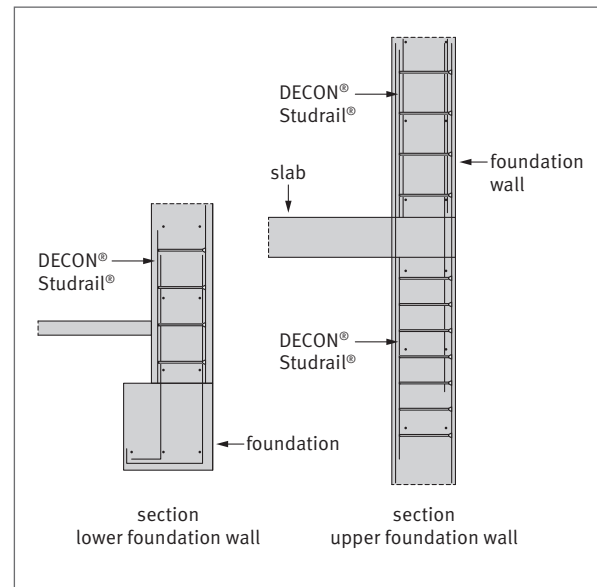

Tie-Downs on Podium Decks

A common structural system is a concrete podium deck separating a parking garage from a wood frame structure above. Hold-down systems are installed at each end of the wood shear walls and must be connected to the concrete slab. Depending on the potential uplift, it is possible that the factored tensile force in the hold-down exceeds the concrete breakout strength and additional reinforcing is required. Studrails® can be used in this instance to increase the anchor capacity.

Advantages compared to alternative designs using stirrups:

- Reduces congestion around the hold-down connection and allows faster installation.
- Distributes tensile forces over a greater critical section to prevent concrete failure.

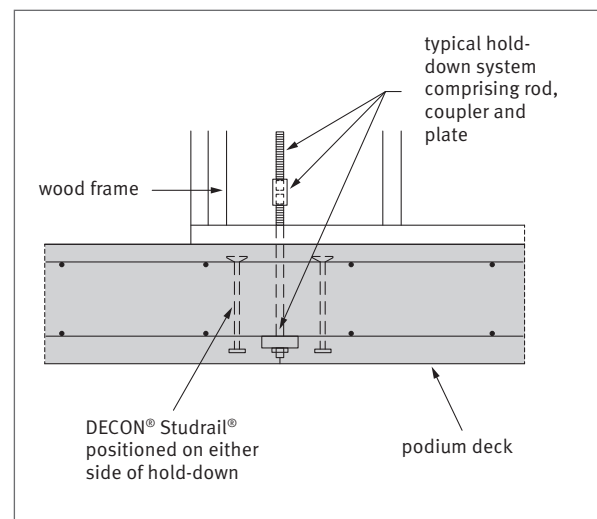

Mat Slabs and Raft Foundations

Studrails® replace hairpin reinforcement at the base of columns and at pile caps with the following advantages:

- Eliminates reinforcement congestion.
- Results in significant savings in time and labor.
- Increases slab punching shear capacity.
- Reduces slab thickness resulting in substantial savings in related material, excavation and pumping costs.

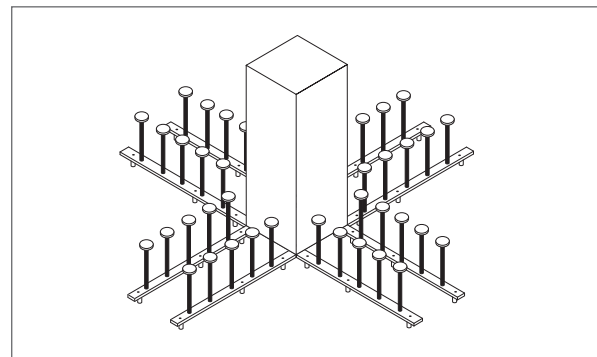

Studrails® at column base and pile cap locations significantly increase punching shear capacities of foundation slabs while allowing reduced slab thicknesses.

Design

Introduction

Studrails® were originally introduced in 1988 as an innovative, economical, quick, and easy solution to improve the punching shear capacity of elevated flat plate floor slabs. Today they are also used extensively in post-tension anchor zones, foundation wall and hold-down applications.

Research revealed that in order to develop the full yield strength of the studs, the area of the anchor head should be a minimum of 10 times the cross sectional area of the stud stem. This configuration enables Studrails® to eliminate the slip commonly seen with stirrup reinforcement. This secure anchorage at the top and bottom of the studs confines the concrete more effectively, thereby resisting the widening of any shear cracks that develop.

Studrails® were initially designed based on the premise that each stud was equivalent to the vertical leg of a traditional stirrup. However, ongoing research has established that Studrails® provide a connection with superior strength and ductility when compared to slabs reinforced with stirrup cages. Therefore, spacing and connection design capacity limits have been increased for the studs, resulting in more efficient and lower-cost designs.

Studrails® are suitable for multiple applications including:

- Punching shear enhancement of RC slabs, PT slabs and raft foundations
- Bursting reinforcement of banded PT anchor zones
- Enhancing concrete pull-out capacity of tie-down systems
- Resisting shear stresses due to lateral soil pressure in foundation walls

Detailed design of Studrails® is made easy by using the latest version of our free design software DECON® EXPERT Studrails® which is downloadable from our website www.deconusa.com.



Governing Codes and Documents

The design procedure for Studrails® is governed by ACI 318, IBC and CSA A23.3 design codes. The Studrail® provisions in these codes were adopted from the recommendations of ACI Committee 421 report ACI 421.1R, which were based on research by DECON and its consultants.

DECON® Studrails® are the subject of ICC ES Evaluation Report ESR-2494, which independently verifies product quality levels and performance, and the City of Los Angeles Research Report RR 25395.



'The Vermont' is a Studrail® project located in Los Angeles, CA. It was completed in 2013.

Design Overview

The following information is provided to give design engineers a general overview of the principles and procedures for design:

1. Notation

Some of the major notation used is as follows:

d = effective depth of the slab.

Defined as the vertical distance from the extreme compression fiber to the centroid of the tension flexural reinforcement running in the x and y directions. When bars of the same diameters and spacing are used in the two directions, d is equal to the slab thickness minus top cover, minus one bar diameter of flexural reinforcement.

d_b = nominal diameter of flexural reinforcing bars (inch or mm)

h = overall thickness of slab (inch or mm)

l_x and l_y = projections of critical section on x and y principal axes (inch or mm)

o_x or g_x = slab overhang dimension beyond the column in the x-direction (inch or mm)

o_y or g_y = slab overhang dimension beyond the column in the y-direction (inch or mm)

s = constant spacing between studs along the Studrail® (inch or mm)

s_0 = distance from the end of the Studrail® to the first stud (inch or mm)



'Centergy North' is a Studrail® project in Atlanta GA, that began construction in 2014.

Section View of Slab

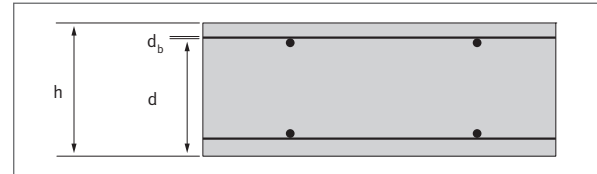

Plan Views of Typical Column Studrail® Layouts

Interior Column

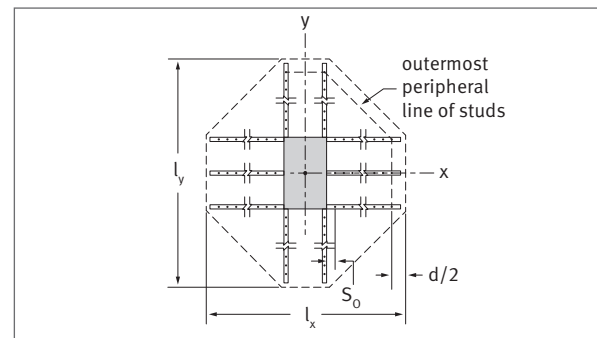

Edge Column

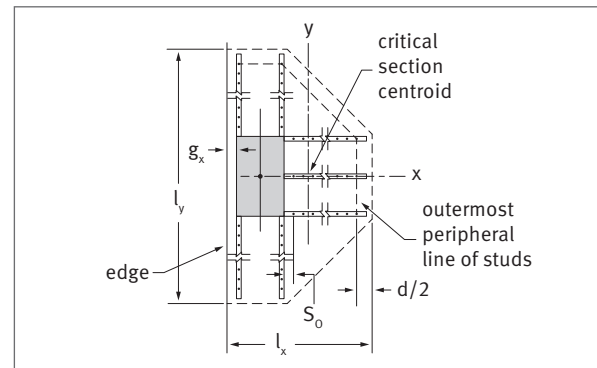

Corner Column

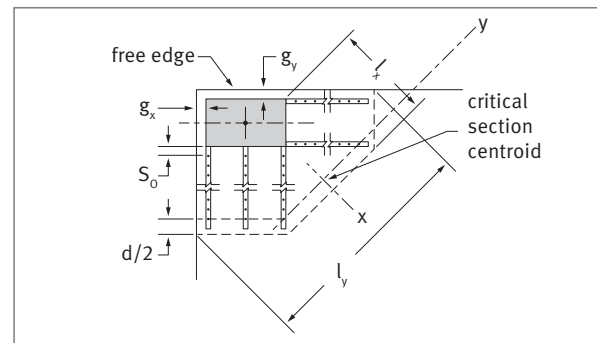

The section and plan views above illustrate critical dimensions and notations for Studrail® design.

2. Basic Design Steps

Step 1

Analyze the critical section at $d/2$ from the column face to determine whether the section is adequate to resist the design loads. If there is not adequate capacity, Studrails[®] are required. In seismic zones, consideration must also be given to ensuring adequate ductility depending on the design combination of gravity loads versus capacity and lateral interstory drift.

Step 2

If Studrails[®] are required, calculate the required Studrail[®] capacity. Select the number of Studrails[®], diameter of studs, and stud spacing to satisfy this criterion.

3. Studrail[®] Selection

Our software enables solutions from a number of product options. Generally, designs using either 3/8" (9.5 mm) or 1/2" (12.7 mm) diameter studs are the most economical in thinner slabs, but when the slab thickness exceeds approximately 11" (280 mm), larger diameter studs may become a better choice.

Minimizing the number of different Studrail[®] sizes will generally result in the most economical design. It is generally better to maintain the same stud diameter throughout a project unless there are a wide range of slab thicknesses. All input loads should be from the same load case. Do not select the maximum vertical shear and unbalanced moments from separate load cases.

When specifying Studrails[®], two spacing values are required: the distance from the column face to the first stud (s_0), and the constant spacing between studs (s). The distance, s_0 , between the column face and the first peripheral line of studs must be small enough so that



Studrails[®] are available in 4 stem diameters and with stud heights to suit the slab.

Step 3

Estimate the number of studs required per rail. Then calculate the concrete shear resistance at a critical section at $d/2$ outside this shear reinforced zone. If the resistance is too low, add another stud and repeat this step. If the resistance is too high, remove a stud and repeat this step until the optimum number of studs is determined.

no cracks are allowed to occur between the column face and the first stud. Also, this initial spacing must be large enough so that the first stud is effective.

The spacing of the studs, s , must be small enough so that every potential shear crack is intercepted by at least one stud. The stud spacing should also be large enough to allow room to place flexural reinforcement or post-tensioning tendons between the stud heads.

It is recommended to use our software to calculate the stud spacing required for the worst case connection and use this spacing on the Studrails[®] throughout.

- The largest allowable spacing (meeting code limitations and loading conditions) will generally make placement of the other reinforcement simpler.
- Matching the stud spacing to the top rebar spacing could simplify installation of the rebar.
- Matching the stud spacing to the post-tension anchor spacing for edge and corner columns could simplify placement of the tendons.

The maximum limits of s_0 and s vary according to slightly different design approaches taken by the applicable codes and documents ACI 318, and CSA A23.3.

The software allows the user to select which design approach to employ.

The range of variations on maximum stud spacing is typically as follows:

$$S_0 \leq 0.35d \rightsquigarrow 0.50d$$

$$S \leq 0.50d \rightsquigarrow 0.75d$$

4. Studrail® Positioning

Studrails® are placed within the critical section of the slab surrounding the columns. At each rectangular column corner, one Studrail® must be placed perpendicular to both column faces. Thus, the minimum number of Studrails® is 8, 6, and 4 for interior, edge and corner columns, respectively.

Studrails® should be placed a minimum of 2" (50mm) from any free edge. Intermediate Studrails® should be spaced equally on edges requiring more than two Studrails®. The maximum spacing between Studrails® according to Clause 11.11.5.3 of ACI 318-11 and ACI 318-14 Clause 8.7.7.1.2 is given as $2d$ in the direction parallel to the column faces. This limit helps ensure confinement of the concrete in the shear reinforced zone.

Similar layouts are recommended for circular columns.

Common situations affecting the critical section are openings and overhangs. Edge and corner columns have slab overhangs if the column is set away from the edge of the slab. The punching shear strength is increased by the presence of any overhang.

The ACI and CSA codes also state that part of the critical section is ineffective when openings are either located at a distance less than 10 times the slab thickness from

the column face, or within the column strips. The critical section for shear at $d/2$ from the column face must be reduced as follows: "...that part of the perimeter of the critical section that is enclosed by straight lines projecting from the centroid of the column, concentrated load, or reaction area and tangent to the boundaries of the openings shall be considered ineffective."

Our software accounts for the effect of openings as defined in the ACI and CSA design.

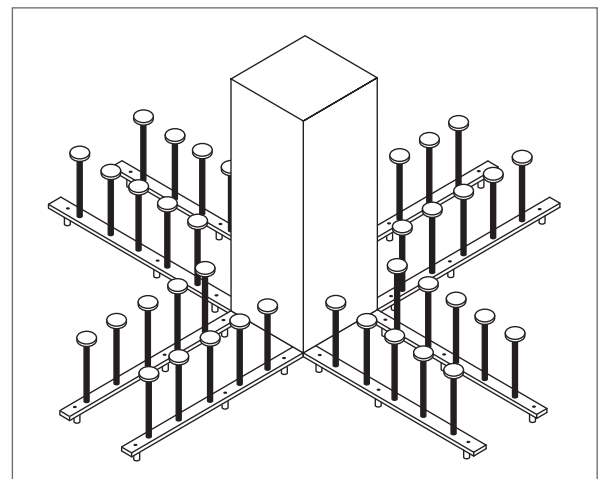

Except for columns located at slab edges, Studrails® are always installed flush to the edges of rectangular columns.

5. Typical Studrail® Layouts

Interior Rectangular Column

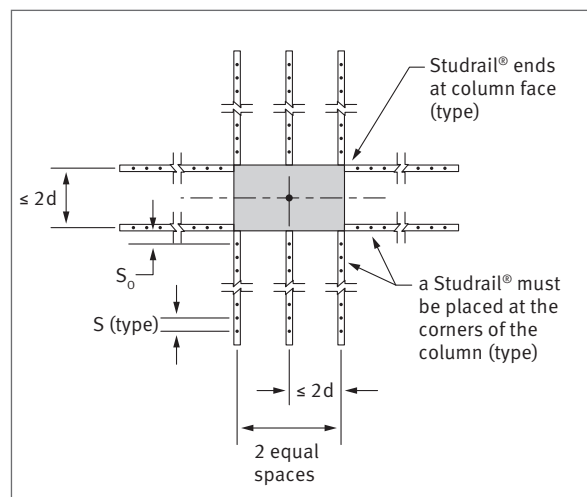

Interior Circular Column

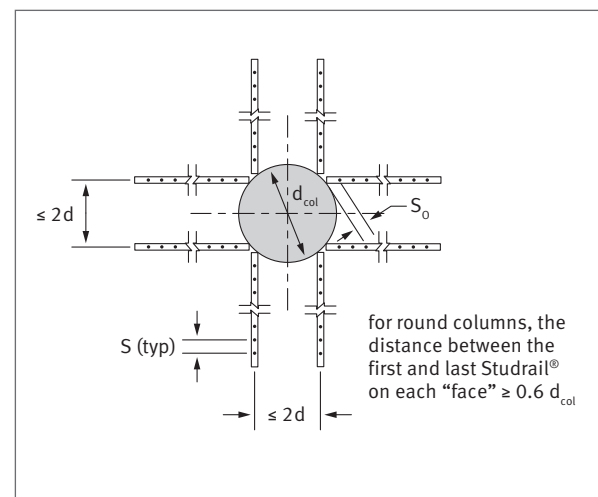

Edge Column

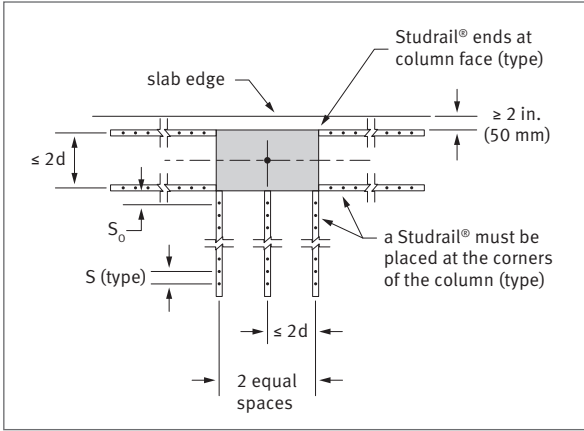

Corner Column

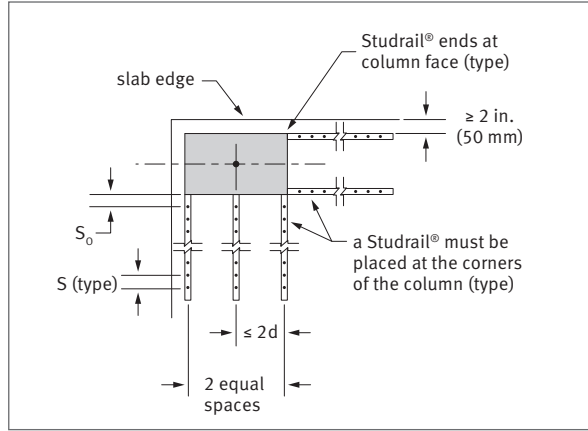

6. Typical Layouts Relative to the Critical Section

Interior Rectangular Column

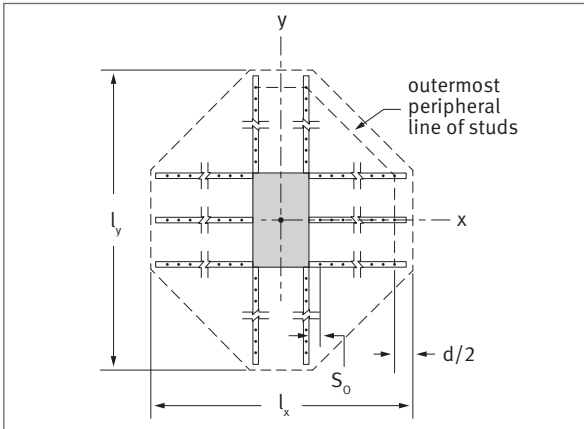

Edge Column

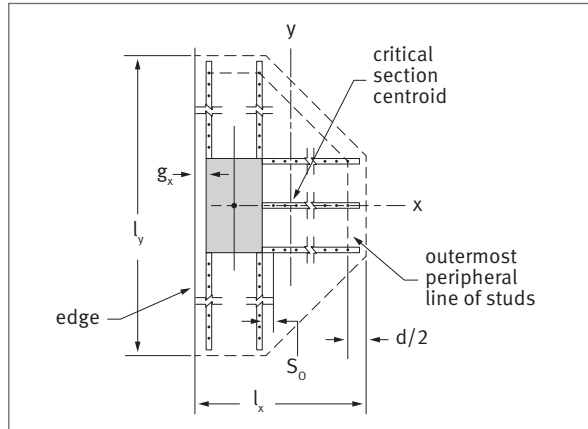

Corner Column

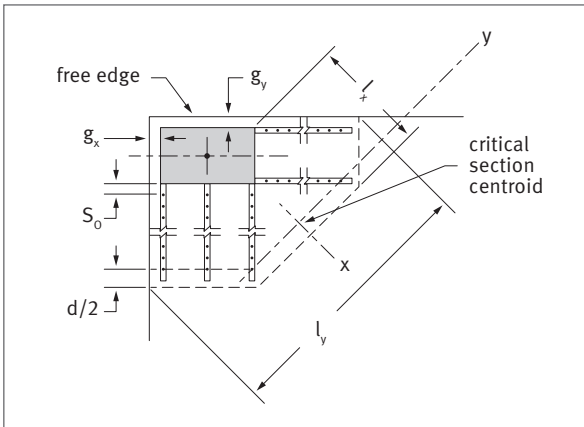

Seismic Design – Improving Slab Ductility

Studrails® also enable the safe transfer of shear stresses resulting from the lateral displacement and cyclic loading observed in seismic events. The secure anchorage of the studs is near the top and bottom surfaces of the slab, resulting in superior confinement of the concrete in the shear-reinforced zone. This results in a ductile connection and provides increased lateral drift capacity when compared to stirrups and traditional reinforcement.

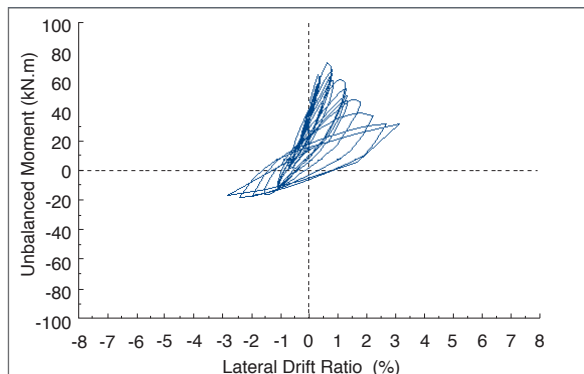

Lateral drift capability with traditional reinforcement

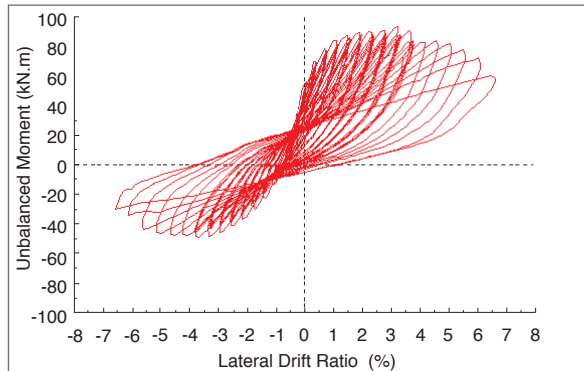

Lateral drift capability with Studrails®



'Wilshire La Brea Apartments' is a Studrail® project located in Los Angeles CA. It was completed in 2012.

Full-scale laboratory tests indicate that the use of properly detailed Studrails® enables slab-column connections to move through lateral story drift ratios much higher than 2.5% even with high gravity load intensity.

IBC 2003 introduced design parameters for ductility punching shear reinforcement at slab-column connections that were not part of the lateral load resisting system. Clause 21.13.6 of ACI 318-11 and ACI 318-14 Clause 18.14.5.1 contains the following design procedure:

Step 1

Determine if slab shear reinforcement is required.

Shear reinforcement is required if:

$$\text{Design story drift} > 0.035 - 0.05 \left(\frac{V_{ug}}{\phi V_c} \right)$$

where:

V_{ug} = factored shear force on the slab critical section for two-way action due to gravity loads

ϕ = strength reduction factor
(0.75 for ACI 318-02 and later)

V_c = nominal shear strength provided by concrete

Step 2

If slab shear reinforcement is required, provide a minimum of:

$$\text{Minimum capacity: } V_s \geq 3.5 \sqrt{f'_c}$$

Minimum extent: 4h from the face of the column



'Ariel Suites' is a Studrail® project located in San Diego CA. It was completed in 2013.

Example – Interior Slab Column Calculation

This example uses the ACI 318-11 design procedure with the following parameters:

- Slab thickness, $h = 8''$
- Concrete cover = $3/4''$ (top & bottom)
- #5 Flexural rebar = $5/8''$ diameter
- Concrete strength, $f'_c = 4000$ psi
- Column size, $c_x = c_y = 20''$
- Loads: $V_u = 160$ kip
- $M_{ox} = 30$ ft-kip = 360 in-kip
- $M_{oy} = 30$ ft-kip = 360 in-kip

Step 1

Check if Studrails® are required.

$$d = h - \text{top cover} - \text{bar diam.} = 8 - 3/4 - 5/8 = 6.625 \text{ in}$$

The plan view below shows the dimensions of a critical section located $d/2$ from the column face.

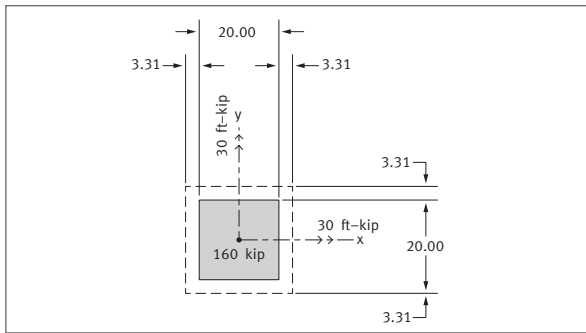

$$l_x = l_y = c_x + d = 20 + 6.625 = 26.625 \text{ in}$$

$$b_o = 2l_x + 2l_y = 4(26.625) = 106.5 \text{ in}$$

$$A_c = b_o d = 106.5(6.625) = 705.6 \text{ in}^2$$

$$\gamma_{vx} = \gamma_{vy} = 1 - \frac{1}{1 + \frac{2}{3} \sqrt{\frac{l_y}{l_x}}} = 1 - \frac{1}{1 + \frac{2}{3} \sqrt{\frac{20}{20}}} = 0.4$$

$$I_x = I_y = d \left(\frac{l_{x1}^3}{6} + \frac{l_{y1} l_{x1}^2}{2} \right)$$

$$= (6.625) \left(\frac{26.625^3}{6} + \frac{26.625(26.625)^2}{2} \right)$$

$$= 8.336 \times 10^4 \text{ in}^4$$

For maximum stress:

$$x = \frac{20}{2} + \frac{6.625}{2} = 13.31 \text{ in}$$

$$y = -\frac{20}{2} - \frac{6.625}{2} = -13.31 \text{ in}$$

Therefore maximum shear stress is:

$$v_u = \frac{V_u}{A_c} - \frac{\gamma_{vx} M_{ux} y}{I_x} + \frac{\gamma_{vy} M_{uy} x}{I_y}$$

$$= \frac{160}{705.6} - \frac{0.4(360)(-13.31)}{8.336 \times 10^4} + \frac{0.4(360)(13.31)}{8.336 \times 10^4}$$

$$= 0.273 \text{ ksi}$$

Checking the stress levels at the other column corners shows the following:

- At $(x, y) = (13.31, 13.31)$, $v_u = 0.227$ ksi
- At $(x, y) = (-13.31, 13.31)$, $v_u = 0.181$ ksi
- At $(x, y) = (-13.31, -13.31)$, $v_u = 0.227$ ksi

The shear resistance is:

$$v_n = \text{Minimum} \left\{ \begin{array}{l} \left(2 + \frac{4}{\beta} \right) \sqrt{f'_c} \\ \left(\frac{\alpha_s d}{b_o} + 2 \right) \sqrt{f'_c} \\ 4 \sqrt{f'_c} \end{array} \right\}$$

$$= \text{Minimum} \left\{ \begin{array}{l} \left(2 + \frac{4}{1} \right) \sqrt{4000} \\ \left(\frac{40(6.625)}{106.5} + 2 \right) \sqrt{4000} \\ 4 \sqrt{4000} \end{array} \right\}$$

$$= 0.253 \text{ ksi}$$

$$\text{Therefore: } v_u > \phi v_n \text{ and } v_u = 4.0 \sqrt{f'_c} < \phi 8 \sqrt{f'_c}$$

Therefore the punching shear is adequate if Studrails® are provided.

Step 2

Check Studrails® layout, stud diameter and stud spacing.

$$v_u \leq \phi (v_c + v_s)$$

Thus:

$$v_s \geq \frac{v_u}{\phi} - v_c$$

$$\geq \frac{273}{0.75} - 3 \sqrt{4000}$$

$$\geq 174 \text{ psi} = 0.174 \text{ ksi}$$

Select 12 Studrails® with $1/2''$ diameter studs at $4-7/8''$ spacing. Therefore:

$$v_s = \frac{A_v f_{yv}}{b_o s} = \frac{12(0.196)(51)}{106.5(4.875)} = 0.231 \text{ ksi}$$

Step 3

Determine the extent of the shear reinforced zone.

Assume 7 studs per Studrail®.

The dimensions of the critical section are shown in plan view of area surrounding the column below:

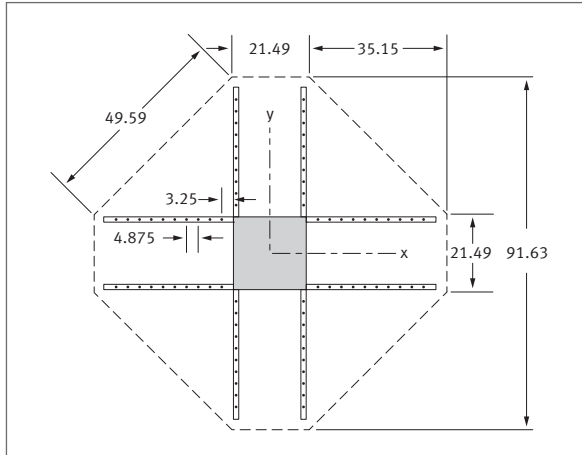

$$\begin{aligned} l_{y1} = l_{x1} &= c_x - b_{\text{rail}} + 2 \left(\frac{d}{2} \tan(22.5^\circ) \right) \\ &= 20 - 1.25 + 2 \left(\frac{6.625}{2} \tan(22.5^\circ) \right) \\ &= 21.49 \text{ in} \end{aligned}$$

$$\begin{aligned} l_{y2} = l_{x2} &= c_x + 2 \left(s_o + 9_s + \frac{d}{2} \right) \\ &= 20 + 2 \left(3.25 + 6(4.875) + \frac{6.625}{2} \right) \\ &= 91.63 \text{ in} \end{aligned}$$

$$\begin{aligned} l &= \frac{1}{2} (l_{x2} - l_{x1}) \sqrt{2} \\ &= \frac{1}{2} (91.63 - 21.49) \sqrt{2} \\ &= 49.59 \text{ in} \end{aligned}$$

$$\begin{aligned} b_o &= 4(l_{x1} + l) \\ &= 4(21.49 + 49.59) \\ &= 284.3 \text{ in} \end{aligned}$$

$$A_c = b_o d$$

$$= 284.3(6.625)$$

$$= 1883 \text{ in}^2$$

$$I_x = I_y = d \left\{ \frac{l_{x1} l_{y2}^2}{2} + \frac{l_{y1}^3}{6} + \frac{l}{4} \left[(l_{y2} + l_{y1})^2 + \frac{1}{3} (l_{y2} - l_{y1})^2 \right] \right\}$$

$$= 1.794 \times 10^6 \text{ in}^4$$

The stress at each corner of the critical section is as follows:

- At $(x, y) = (10.75, 45.81)$, $v_u = 0.082$ ksi
- At $(x, y) = (45.81, 10.75)$, $v_u = 0.088$ ksi
- At $(x, y) = (45.81, -10.75)$, $v_u = 0.089$ ksi
- At $(x, y) = (10.75, -45.81)$, $v_u = 0.089$ ksi
- At $(x, y) = (-10.75, -45.81)$, $v_u = 0.088$ ksi
- At $(x, y) = (-45.81, -10.75)$, $v_u = 0.082$ ksi
- At $(x, y) = (-45.81, 10.75)$, $v_u = 0.080$ ksi
- At $(x, y) = (-10.75, 45.81)$, $v_u = 0.080$ ksi

Therefore, the maximum stress occurs at $(x, y) = (45.81, -10.75)$ and was calculated by:

$$\begin{aligned} v_u &= \frac{V_u}{A_c} - \frac{\gamma_{vx} M_{ux} x}{I_x} + \frac{\gamma_{vy} M_{uy} y}{I_y} \\ &= \frac{160}{1883} - \frac{0.4(360)(-10.75)}{1.794 \times 10^6} + \frac{0.4(360)(45.81)}{1.794 \times 10^6} \\ &= 0.089 \text{ ksi} \end{aligned}$$

The stress resistance is:

$$\phi v_n = \phi v_c = 0.75(2) \sqrt{4000} = 0.095 \text{ ksi}$$

Therefore: $v_u \leq \phi v_n$

Design summary:

- 12 Studrails® each with seven, 1/2" diameter studs
- Spacing: $s_o = 3.25$ in, $s = 4.875$ in
- Overall height of Studrail® (OAH) = 6.5 in
- Overall length of Studrail® (OAL) = 35.75 in

Example – Design of Studrails® for Ductility

This example shows the design of Studrails® for ductility. The interior column design examined in the first example is used again but with a lower loading. The lower loading would allow the connection to be constructed without shear reinforcement if the ductility requirement of IBC 2012 and Clause 21.13.6 of ACI 318-11 did not have to be met. However, due to this requirement Studrails® would be required as follows.

Parameters:

- Slab thickness, $h = 8''$
- Concrete cover = $3/4''$ (top & bottom)
- #5 Flexural rebar = $5/8''$ diameter
- Concrete strength, $f'_c = 4000$ psi
- Column size, $c_x = c_y = 20''$
- Loads: $V_u = 100$ kip

Step 1

Check to determine whether Studrails® are required.

The plan view below shows the dimensions of critical section located $d/2$ from the column face.

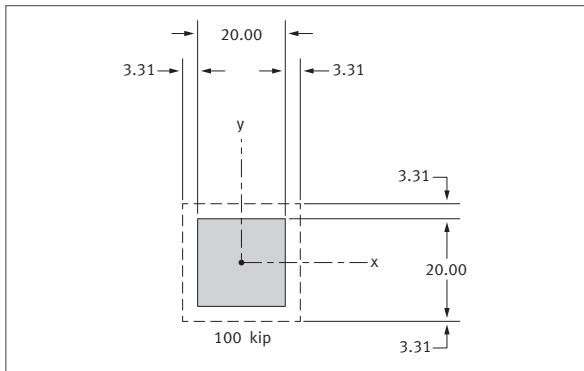

Parameters of the critical section at $d/2$ are given in the first example on page 14. Since the loading is concentric, the stress level will be the same along the entire critical section.

Therefore, the maximum shear stress is:

$$V_u = \frac{V_u}{A_c} = \frac{100}{706.5} = 0.142 \text{ ksi}$$

The shear resistance is:

$$v_n = \text{Minimum} \left\{ \begin{array}{l} \left(2 + \frac{4}{\beta} \right) \sqrt{f'_c} \\ \left(\frac{\alpha_s d}{b_o} + 2 \right) \sqrt{f'_c} \\ 4 \sqrt{f'_c} \end{array} \right\}$$

$$= \text{Minimum} \left\{ \begin{array}{l} \left(2 + \frac{4}{1} \right) \sqrt{4000} \\ \left(\frac{40(6.625)}{106.5} + 2 \right) \sqrt{4000} \\ 4 \sqrt{4000} \end{array} \right\}$$

$$= 0.253 \text{ ksi}$$

Therefore: $v_u < \phi v_n$ but Studrails® are required due to IBC 2012.

Step 2

Select Studrail® layout, stud diameter, and stud spacing.

$$v_s \geq 3.5 \sqrt{f'_c} = 0.221 \text{ ksi}$$

Select 12 Studrails® with $3/8$ in. diameter studs with $2 \ 3/4$ in spacing. Therefore:

$$v_s = \frac{A_v f_{yv}}{b_o s} = \frac{12(0.110)(51)}{106.5(2.75)} = 0.230 \text{ ksi}$$

Step 3

Determine the extent of the required shear reinforced zone.

The Studrails® must extend a minimum $4h$ from the column face. Therefore, 13 studs are required so that the last stud is $33''$ from the column face and the Studrail® length is $35 \ 3/4''$.

Software

Stud and rail configurations of Studrails® are designed using our highly acclaimed design software DECON® EXPERT Studrails®. Studrail® slab reinforcement around interior, corner, and edge columns can be designed. The software allows columns in rectangular and circular formats to be accommodated plus allowances for post-tensioning, and openings.

The latest version of our software is available for free download at www.deconusa.com. To install the software, double-click on the file and follow the on-screen instructions. You will need to agree to the disclaimer in order to install it. This disclaimer must also be acknowledged every time you run the software.

Our software enables the engineer to select either US or metric measurements for structure geometry and loading conditions. It provides Studrail® design output according to any of the following standards:

USA:

- ACI 318

Canada:

- CSA A23.3

International:

- ETA-13/0136 (EN 1992-1-1)
- SIA 262:2013

The design is constantly updated as the input fields are modified. The input data is checked as it is typed. Any errors will be highlighted red.

The software will first check if the slab column connection is adequate without any shear reinforcement. If reinforcement is required, the software will then check if Studrails® are suitable to transfer the shear loads based on the limitations of the selected design code. If the user has not selected any automatic design parameters, the software will analyze the connection using the given input, and the results will be displayed. Error messages prompt the user to modify the input.

If “Automatic” is selected for any of the input, the software will optimize the design of the connection as follows (only the automatic parameters will be adjusted). The software first determines the minimum number of



Studrails® that are required based on the ratio of each column face to the slab effective depth. There must be a minimum of two Studrails® placed at the corners of the column on each column face, with a spacing no greater than twice the slab effective depth.

The software then calculates the maximum stud spacing that is allowed based on the selected design code. If the required capacity is inadequate, the software will reduce the stud spacing and check the capacity again until a viable result is obtained. If it is necessary to achieve the required capacity, additional Studrails® may be added. If the stud diameter is set to automatic, the software performs this subroutine for each of the four available stud diameters, and the most economical result is selected. Please note that this optimization is for the individual connection, not for the entire project.

Finally, the software determines how far the Studrails® must extend such that the concrete outside the shear reinforced zone is adequate to resist the punching shear stresses.

If possible, it is recommended that the designer should try to use same stud size and spacing throughout the project. This is typically the best option because unit pricing of the Studrails® is reduced with larger quantities. Placement errors on the jobsite are also minimized by maintaining the same stud diameter and spacing at each column location.

The following illustrations provide a general introduction to the features of the DECON® EXPERT Studrails® design software.

User Interface

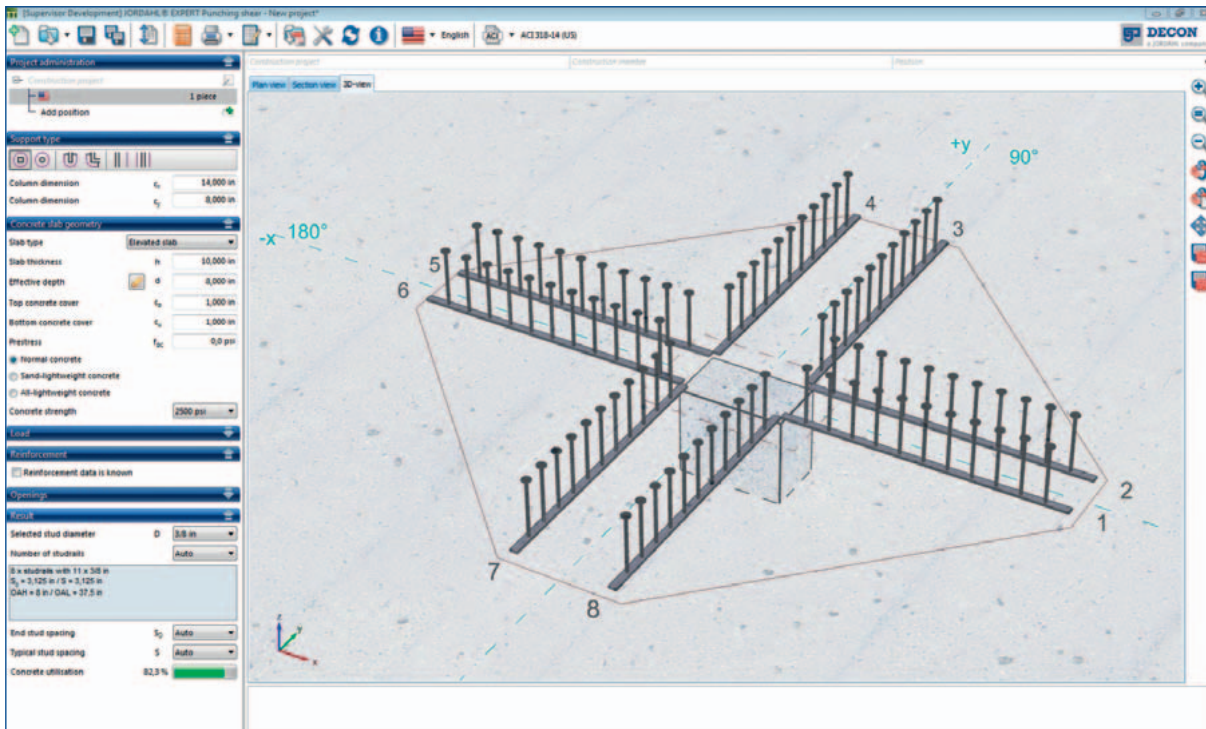

Design Codes and Languages

Design codes, languages, and units can be selected according to user requirements.

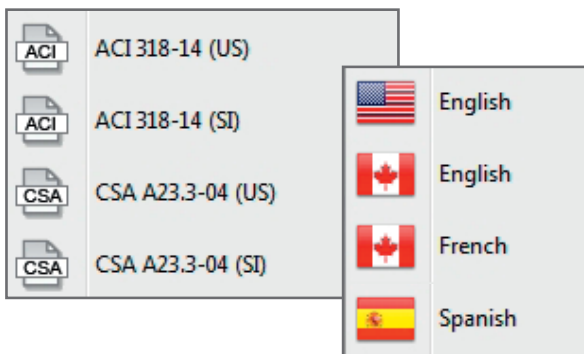

Support Types

A wide selection of column and wall support options can be selected by the user. These can be applied to both elevated slabs and foundation slabs.



support types	rectangular	circular
inner column	yes	yes
edge column	yes	yes
corner column	yes	yes
end of wall	yes	
corner of wall	yes	
wall one-sided	yes	
wall double-sided	yes	

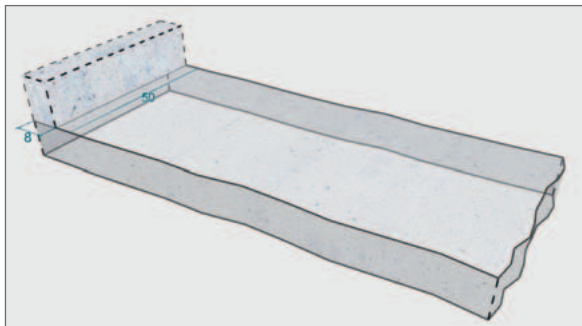
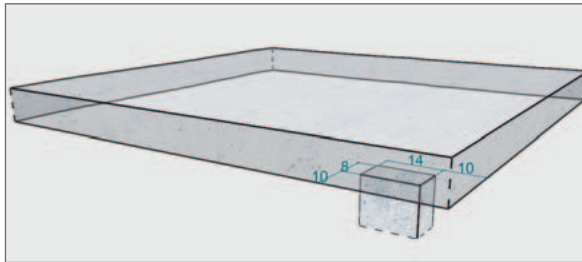

Examples of two structural configurations.

Project Administration

All design and product information can be easily stored and filed by project.

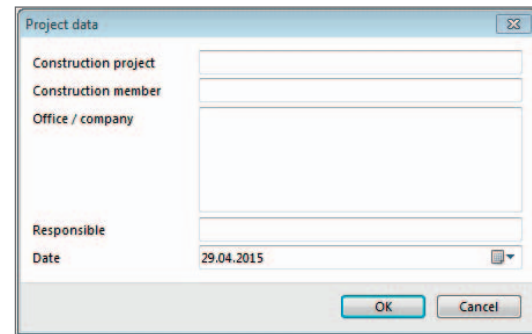
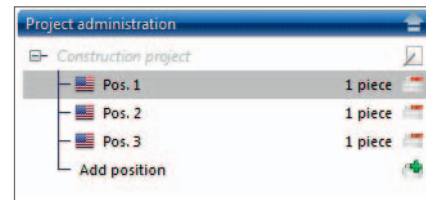

Concrete Slab

Variations in slab type, dimensions and concrete strengths are accommodated by user inputs.

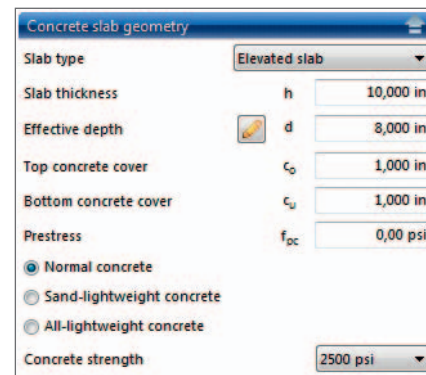

Openings

The user is able to input variations in the types and dimensions of slab openings.

No.	Position x	Position y	Width	Height
□ 1	-18 in	11 in	8 in	4 in
○ 2	12 in	-14 in	8 in	8 in

Total angle of all openings $\Sigma\Delta\alpha$ 45,61°

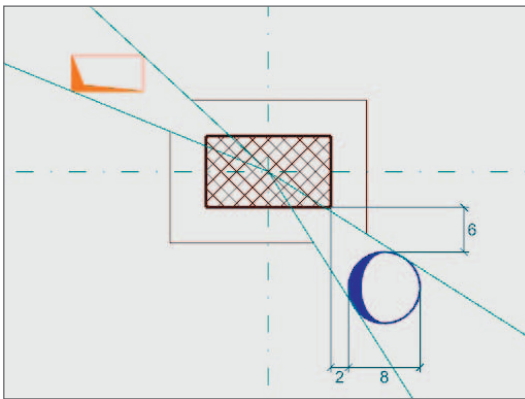

An example of typical software graphics for openings.

- The effects of openings are checked automatically.
- Openings can be inserted or moved at the click of a mouse.
- The program automatically detects any opening overlaps.
- Changes to opening dimensions are immediately shown in the software graphics.
- The locations of openings are included on the printout drawing.

Update Service



The design software provides an automatic update service.

Load

Punching shear, unbalanced moments and seismic loads are accommodated in this section of the software.

Load		
Punching shear load	V_u	150000 lbf
Unbalanced moment X	M_{ux}	0,0 lbf-ft
Unbalanced moment Y	M_{uy}	0,0 lbf-ft
<input type="checkbox"/> Seismic loading		

Reinforcement

Inputs in this section accommodate variations in reinforcement design, and provide automatic calculation of the effective depth.

Reinforcement		
<input checked="" type="checkbox"/> Reinforcement data is known		
x-direction		
Diameter of reinforcement	ϕ_x	#3
Distances	s_x	8,000 in
y-direction		
Diameter of reinforcement	ϕ_y	#4
Distances	s_y	8,000 in

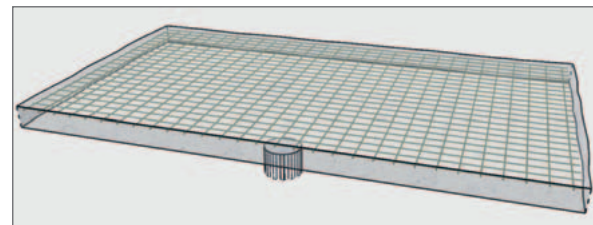

Typical reinforcement graphics from the software.

Views

Typical plan and section views from the software are shown below.

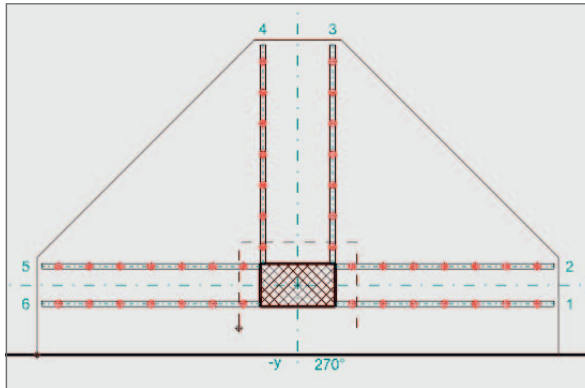

Plan view

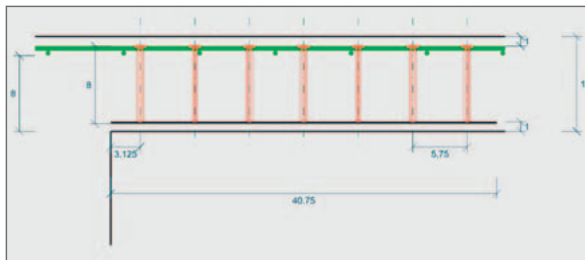

Section view

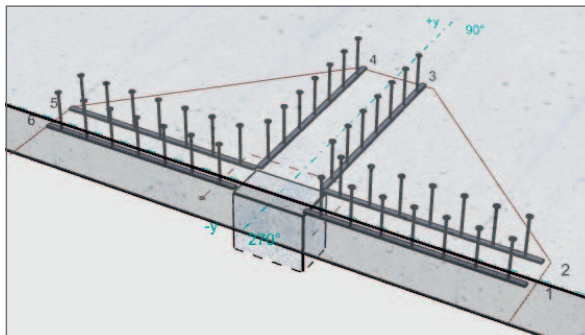

3D view

Data export



Drawings can be exported as *dwg, *dxf, *bmp or *jpg file.



Printouts

The software provides a facility to create reproducible printouts of all the data relevant to the calculation process.

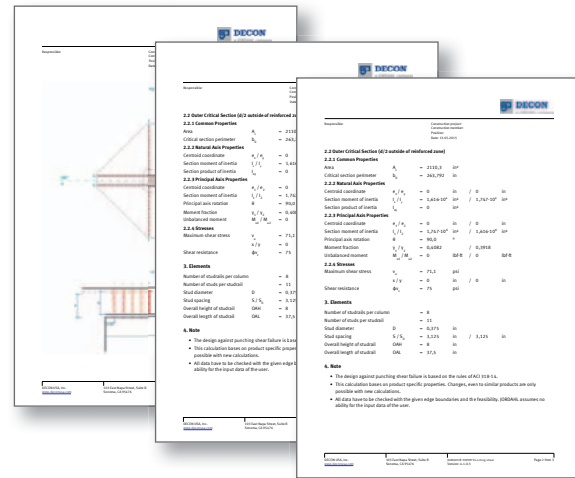

Data Set and Layouts

The most important data relating to each load condition can be collated.

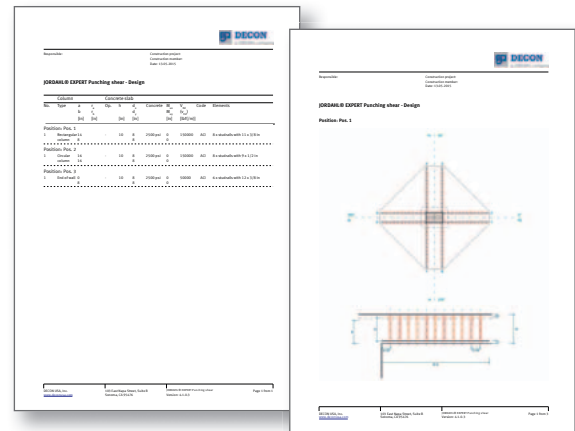

Specifying and Ordering DECON[®] Studrails[®]

Specification Text

Studrails[®] should be specified in “Section 3200 – Concrete Reinforcement” of the project documents using wording similar to the following:

Shear Reinforcement at the slab column connection as shown on the drawings and details, shall be Studrails[®] as manufactured by DECON and detailed in ICC ESR-2494. The complete and finished Studrail[®] shall be ICC ES-evaluated and welding shall take place in an ICC ES-audited facility. Studrails[®] shall conform to the latest update of ASTM A1044.

Please include our phone number on the drawings and in the specification manual so that bidders know how to locate our offices for price quotations.

Dimensions

The following drawing and table provides the dimensions of studs that are available.

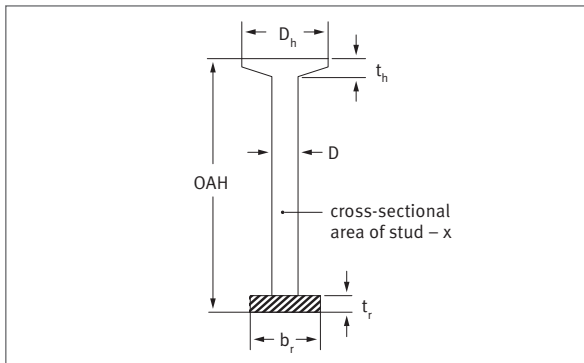

The overall height (OAH) of the stud is determined by the concrete thickness and cover requirements.

D	In. (mm)	3/8 (9.5)	1/2 (12.7)	5/8 (15.9)	3/4 (19.1)
x	In. (mm)	0.110 (71)	0.196 (127)	0.307 (199)	0.442 (287)
D _h	In. (mm)	1.19 (30.1)	1.58 (40.2)	1.98 (50.2)	2.37 (60.2)
t _h	In. (mm)	0.21 (5.3)	0.28 (7.1)	0.35 (8.9)	0.42 (10.7)
b _r	In. (mm)	1 (25.4)	1-1/4 (31.8)	1-3/4 (44.5)	2 (50.8)
t _r	In. (mm)	3/16 (4.8)	1/4 (6.4)	5/16 (7.9)	3/8 (9.5)
Min. OAH	In. (mm)	3.5 (90)	3.5 (90)	4 (100)	4.5 (115)

Material

The rails of Studrails[®] are low carbon steel type 44W. The strength and ductility requirements are:

- Yield strength: 44,000 psi min. (300 MPa)
- Tensile strength: 65,000 psi min. (450 MPa)
- Elongation in 8 in.: 20% minimum

Studrail[®] headed studs are made from low carbon steel, C1010 to C1018 in accordance with ASTM A108.

The strength and ductility requirements are:

- Yield strength: 51,000 psi minimum (350 MPa)
- Tensile strength: 65,000 psi minimum (450 MPa)
- Elongation in 2 in.: 20% minimum
- Reduction of Area: 50% minimum

Technical Information

- Studrails[®] meet the requirements of ACI 318- 11, ACI 421.1R-08, ACI 318-14, CSA A23.3 and IBC 2012
- They are the subject of ICC ES Evaluation Report ESR-2494, and the City of Los Angeles Research Report RR 25395
- Semi-automatic stud welding process according to AWS D1.1 and CSA W59. Certified by the Canadian Welding Bureau
- Stud head/stem cross sectional area ratio 10:1
- Made in 4 stem diameters – 3/8” (9.5mm), 1/2” (12.7mm), 5/8” (15.9mm), and 3/4” (19.1mm)

Ordering Studrails[®]

Studrails[®] are designed and manufactured to meet the specific requirements of each project. The basis of each Studrail[®] design is calculated using the current edition of our design software, which allows the structural engineer to specify the dimensions, locations, and quantity of Studrails[®] required.

DECON is pleased to use blueprints supplied by the customer to provide a take-off service that lists the sizes and quantities of Studrails[®] needed for the project. Customers are encouraged to contact their local DECON representative to receive a quotation or place an order. Please visit www.deconusa.com or www.decon.ca for up-to-date contact information in your location. Quotations include preparation of submittal documents, delivery, and installation accessories.

Installation of DECON® Studrails®

Securing Studrails® to the Formwork

In all cases the Studrails® must be installed at ninety degrees to the formwork. They are secured to the formwork using nails through DECON® Clip Chair or Star Chair spacers. Star Chair spacer locations are predetermined while Clip Chair spacers are installed under the rail at a minimum of 2" (50mm) from each end and then evenly along the length.

DECON® Clip Chairs

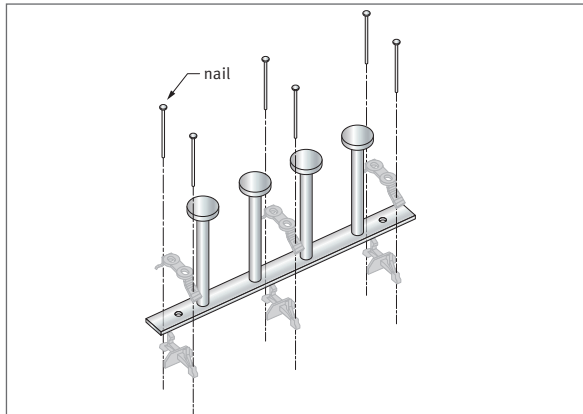

Space Clip Chairs evenly along the Studrail® and secure the complete unit to the formwork with 4d to 6d nails.

DECON® Star Chairs

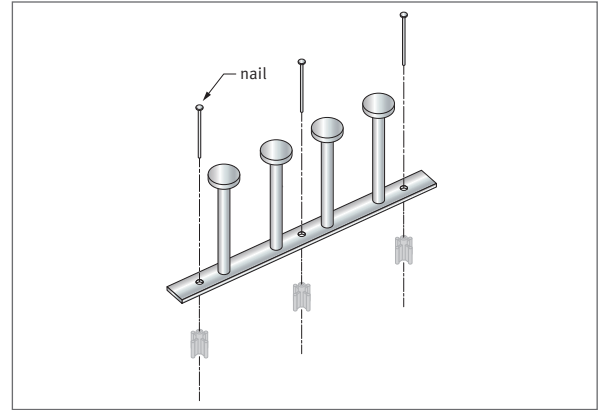

Press Star Chairs into the location holes in the Studrail® and secure the complete unit to the formwork with 4d to 6d nails.

Quantity of Star Chairs or Clip Chairs Per Rail

Rail Length	Number of Chairs
0 – 19-3/4"	2
20" – 39-3/4"	3
40" – 59-3/4"	4
60 – 79-3/4"	5
≥ 80"	6

DECON® Studrail® Positioning

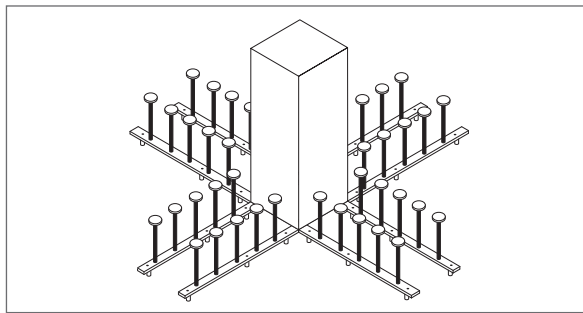

Except for columns located at slab edges, Studrails® are always installed flush to the edges of rectangular columns.

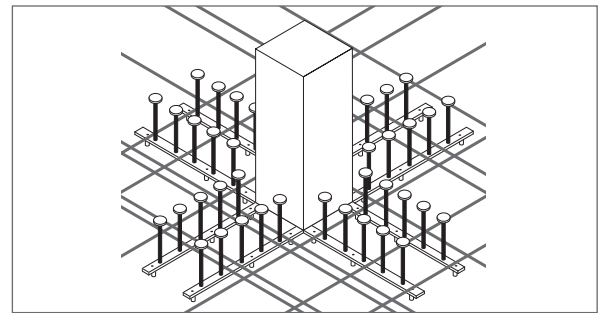

PT tendons and any additional reinforcement run between stud positions, and are placed after the Studrails® are installed.

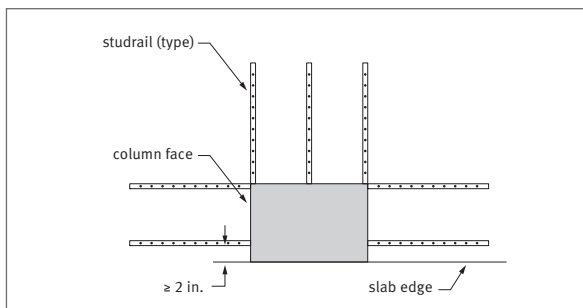

At slab edge columns the forward Studrails® are set 2" (50mm) min. from the slab edge.

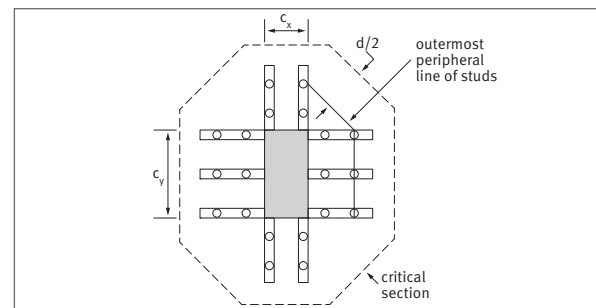

Studrails® are evenly spaced along column edges requiring more than two Studrails®.

Advice



DECON & JORDAHL Experts

When you contact us for advice on either DECON or JORDAHL products you will receive a very high standard of service. Whether from the point of view of calculations, general technical advice/service or the development of customized solutions – competent and experienced product specialists offer you state-of-the-art, versatile and customized solutions for your projects.

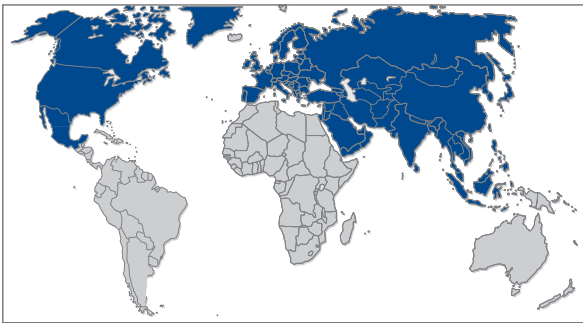

Throughout North America and Around the World

Exceptional performance and high quality is in demand everywhere. For this reason, JORDAHL and DECON products have been used around the world for many years, and have repeatedly proven themselves on a huge number of projects. Using a network of subsidiary companies and distributors, we can also guarantee the highest standards of global customer service when it comes to delivery.

Disclaimer of Warranties

This catalog and the design software program are design aids intended for use by a qualified person who takes full responsibility for the design of the structure.

The design software program purchased or received from either DECON USA or CONTINENTAL is sold or conveyed 'as-is' without a warranty of any kind, either express or implied, including but not limited to implied warranties of merchantability, or fitness for a particular purpose.

DECON USA, Inc., CONTINENTAL, Inc.

The University of Calgary, Dr. Dilger, Dr. Ghali, and JORDAHL GmbH are not responsible for any damages whatsoever which may be incurred by the purchaser, user, or any other person by reason of misuse or any defect in this catalog or the design software program.

Main Sales Office

DECON USA, Inc.
103 East Napa Street, Suite B
Sonoma, CA 95476

Tel: 866 332 6687
Fax: 707 939 9024
www.deconusa.com

Main Engineering Office

DECON USA, Inc.
11 Professional Village Circle
Beaufort, SC 29907

Tel: 800 975 6990
Fax: 843 525 1729
www.deconusa.com

Canada

CONTINENTAL, Inc.
35 Devon Road
Brampton, Ontario, L6T 5B6

Tel: 800 363 3266
Fax: 905 458 5354
www.decon.ca